

SURGING AND BLOW OUT OF LOOP SEALS IN A CFBC BOILER

By K.K.Parthiban – Venus energy audit system

This is a very interesting case to us, wherein we had the opportunity to resolve the problem of surging and blow out of the loop seals in a CFBC boiler. The cyclones were subject to oscillations and the oscillations were being transmitted to the boiler supporting structure. This case was a Chinese make CFBC boiler feeding steam to a 60 MW power plant. This case was handled by few others and the solution was not found out. It was then our turn. With the sustained co-operation of the plant manager, plant engineers, boiler operators and the owner of the plant, the problem was resolved.



Plant history & the earlier incidents

The cyclone oscillations problem was experienced in the past one few occasions. The problem was overcome by resorting to operating of the CFBC boiler with very less furnace inventory. Both the flue gas was flowing through loop seals as well. The boiler was being operated with minimum bed material for a long time. As the load went up in the recent times, the bed inventory had to be increased. Then the problem begun. The flow of material from loop seal had not been proper.

1. There had been a major plant overhauling about 10 months ago. At this overhaul, the furnace nozzles and loop seal nozzles were replaced. Refractory at downleg, return leg and loop seal were repaired.
2. Vibration in cyclone became a serious thing after this. The flow of material in down legs had not been smooth. Operators or other consultants did not identify the cause as the essential instrumentations related to lower bed height, upper bed height, loop seal height, loop seal airflow were not proper.
3. There had been an explosion too as the furnace behavior had been erratic. The bed had been defluidised due to flow of large amount of material accumulated at the cyclone. There was high CO formation. There had been a major damage to the pressure parts and the buckstays.
4. Boiler restarted after correction of waterwall and replacement of buckstay beams. The problem had remained to be severe.
5. Plant engineers presumed that there had been improper refractory work at the loop seal and the refractory was touched upon to very close tolerances.

Vibration measurement

The vibration spectrum readings indicated that the frequency of vibration was at 3.5 to 5 Hz. It did not come under category of vibration. It was oscillation due to combustion / surging of solids in downleg. There had not been any acoustic vibration / sonic vibration. The steam cooled furnace outlet duct hanger rods exhibited the oscillation due to its long and small size hanger rods. The interconnecting pipe to & from cyclone showed the oscillation. The unsupported long drain pipes attached to Loop seal windbox and the drain to Loop seal amplified the oscillation. On the whole it was an unacceptable situation.

Operational observations

The boiler operation was observed by us for some

days. We could understand the oscillation was due to breaking of the loop seal. There was flow of material from loop seal periodically. As such good amount of material was hiding inside the conical portion of the cyclone. It was not in the downleg. The loop seal temperatures between left & right differed considerably. Many times, Loop seal temperatures were more than the cyclone inlet gas temperature. We tried to increase the furnace inventory by resorting to the following steps.

- Reducing the particle size from – 10 mm to – 6 mm from coal handling plant.
- The fines were being removed from the bottom ash drains. We advised that the drain gates must be partly open so that fines could be retained in the furnace.
- We tried to use the dumping air from loop seal blower to the maximum extent. There was no VFD for loop seal blower. The butterfly valves in the air flow lines to loop seals could not help in finer control of the air to loop seals. They were of larger size. Hence further finer adjustments could not be done.

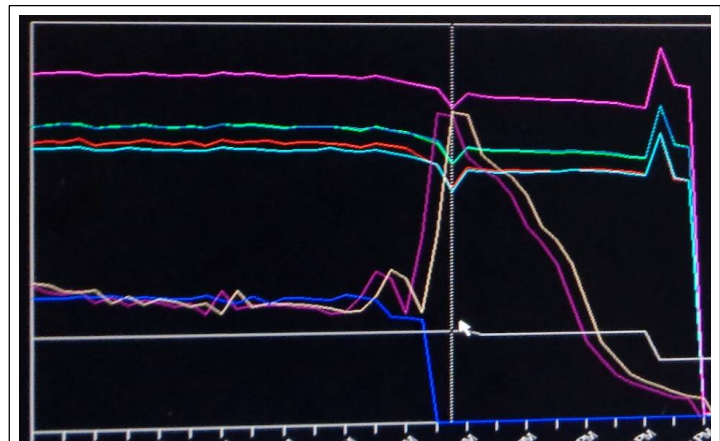

Figure 2: The trend shows large amount of bed material flow into the furnace. The left and right WB pressures surged from 7 Kpa to 15 Kpa. So much material was hiding in the cyclone.

As the seals were not getting set, the plant was shut on advise from higher management for inspection. As the boiler was shut, it became clear that considerable material had been hiding inside the cyclone. The loop seal was not working at all. There was good amount of flue gas flow through the loop seal.

Vibration measurement in cyclone & furnace				
Displacement is measured in 'mm'				
Frequency is measured in 'Hz'				
Measuring mode-FFT				
Date			17.02.2018	
Load			130 TPH	
			Peak dis	Freq at peak
Cyclone	LHS cyclone	Location 1	0.5	3.5
		Location 2	0.19	6
	RHS cyclone	Location 1	2.4	5
		Location 2	0.95	5.5
Furnace	LHS buckstay	Location 1	-	-
		Location 2	-	-
	RHS buckstay	Location 1	-	-
		Location 2	-	-
Condition of loop seal			With loop seal broken	

Figure 1: Vibration measurements.

Review of old log sheets – See annexure 2

The log sheets of the boiler in previous years were reviewed.

- The seal pressure was at 36 Kpa only. Subsequently the seal pressure had gone up to 56 Kpa. This led to the Loop seal break. Once the Loop seal breaks, the combustion would take place inside the cyclone also, leading to oscillations.

BED	FL DP		FURNACE			J SEAL LEFT		J SEAL RIGHT		
	temp.	pr.	L/R	DP L/R	O/L pr.	O/L temp	tem F/B	pr.F/B	temp.F/B	pr.F/B
784	5.3	5.5	5.45	6.45	-0.16	750	746	31	777	29
			5.34	0.34		764	741	31	760	31
779			5.52	0.48	-0.18	755	751		776	
			5.53	0.37		766	745		761	
783			5.52	0.44	-0.16	751	750	31	784	29
			5.53	0.37		772	744	31	767	31
783	5.2	5.3	5.52	0.44	-0.16	751	750	31	784	29
			5.53	0.37		772	744	31	767	31
784	5.5	5.4	5.33	0.48	-0.16	750	750		783	
			5.36	0.38		774	743		766	
784	5.3	5.17	5.17	0.42	-0.17	753	750	31	784	29

Figure 3: The old data when Chinese operated the plant.

- The bed height was purposely kept less, only 5 – 5.5 Kpa, by Chinese during initial operational period. This brings instability for operation. The DESH spray will be high, as the heat transfer to furnace wall tubes is greatly reduced due to absence of furnace inventory. In CFBC boiler operation, the upper bed inventory is vital. Otherwise the furnace temperatures keep oscillating, depending on minor variations in coal feed rate / coal GCV. This will be suspension firing carrying a risk of explosion. The LOI of fly ash was reported to be good, because it was a high ash coal. Bed ash LOI was high, above 6%.

Review of old screen shot at full load

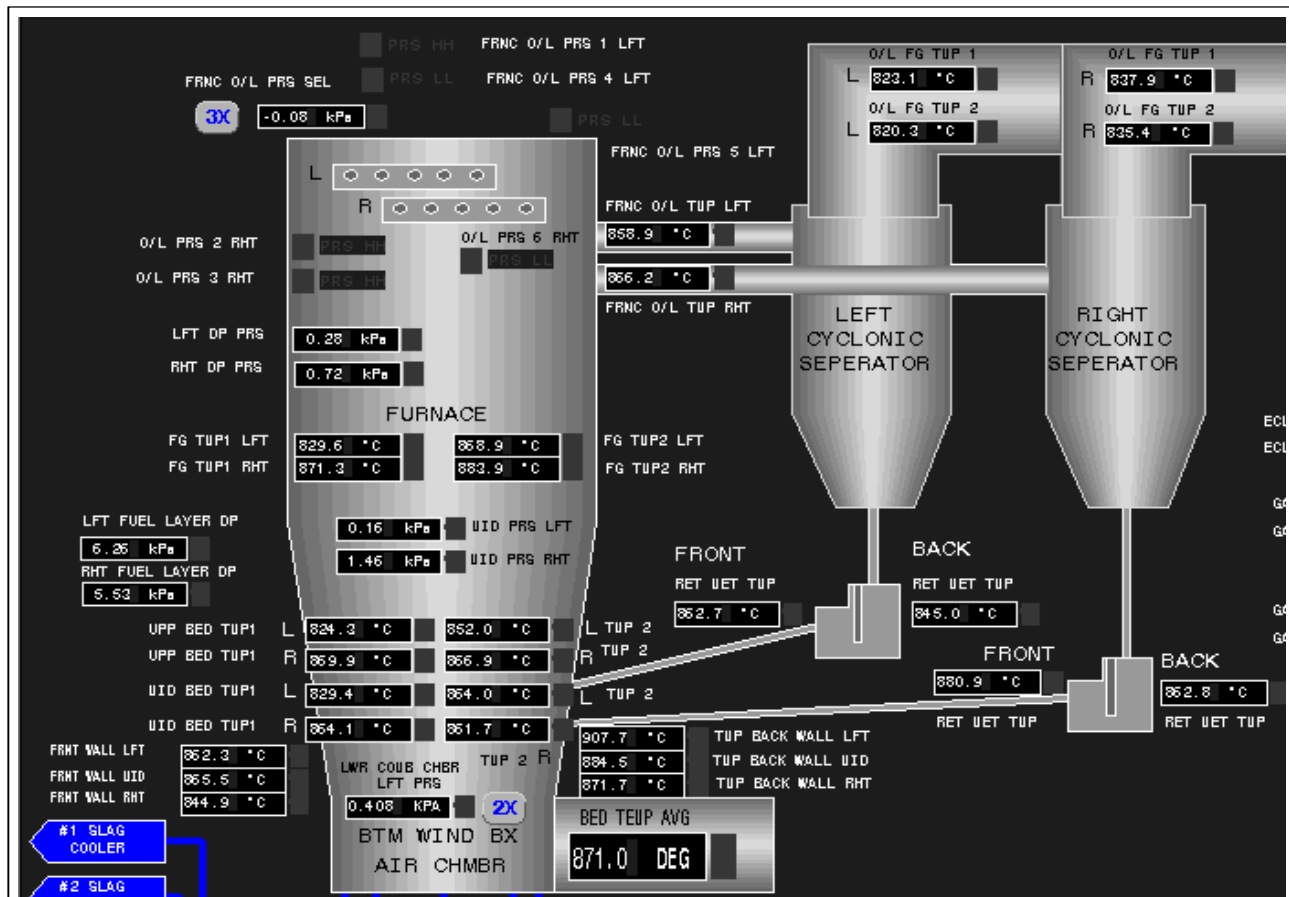

Figure 4: Screen shot at full load two years ago.

The above was the screen shot shared by the engineers during the operation at full load two years ago. The loop seal pressures were at 36 Kpa only at this time. The dump valve opening was at 23.5%. The windbox pressure however was seen to be only 6 Kpa. This would have left very less inventory in the cyclone. The average bed temperature is 871 deg C with 3 % oxygen. The upper bed DP is seen to be 0.72 Kpa on one side and 0.28 Kpa on the other side. There must have been internal recirculation. The cyclone pressure drop was seen to be 0.77 Kpa. The loop seal temperatures were lower or comparable to cyclone inlet gas temperatures. We could infer that right side seal was broken as its cyclone outlet gas temperature was more than the left cyclone. The windbox pressure was too less.

The point driven by one of the operators was that the boiler was operating with old loop seal nozzles at this time. There might have been minor seal break – upward gas flow in the right side cyclone. But the oscillations might not have been experienced, due to operation with less bed inventory.

Work performed in our presence during the shut down

1. The pressure tappings in furnace and in flue path were found with arrangements for continuous purging. During our presence continuous purging system was hooked for important instruments. The instrumentation team immediately took up and corrected the following essential signals. The purging air flow was set at 2.5 m³/h at the rotameters. The initial pressure values due to purging / zero errors were recorded in logbook.
 - Main WB pressures - left & right
 - Bottom bed pressure (overall bed height) – left &
 - Upper bed DP (lean bed height) – left & right
2. Flue gas sampling points were added at several locations. Grid gas sampling provision was added in economiser outlet.
3. Ash sampling provision was added at ESP field 1 ash hopper. This was required for sieve analysis of the fly ash to identify carry over of + 90 / + 75 / + 45 micron particles. The rise in + 90 microns particles indicate the Loop seal break / inadequacy of seal height at downleg.

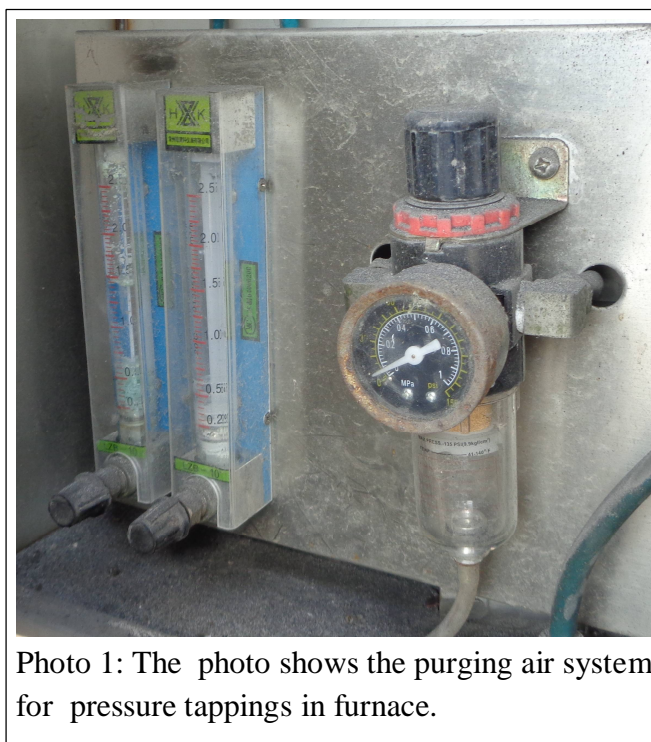
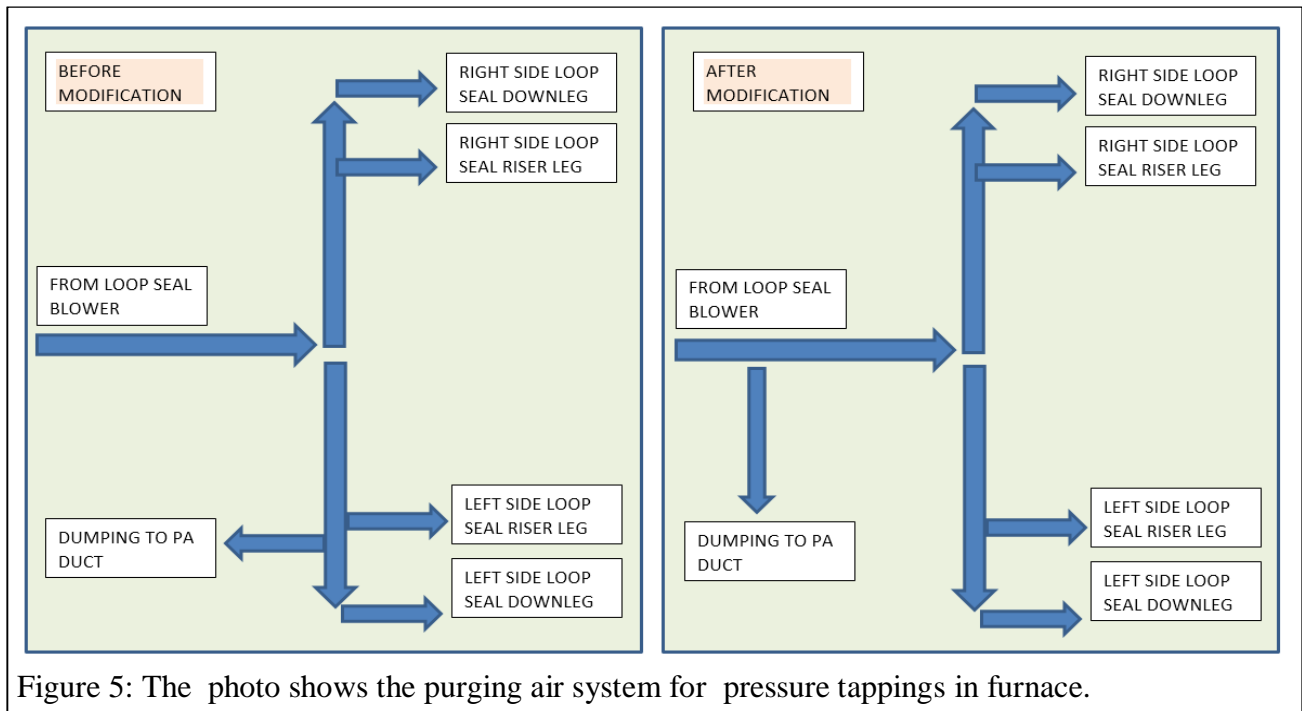

Photo 1: The photo shows the purging air system for pressure tappings in furnace.

Loop seal cold operation

1. On cold operation of loop seal, difference in air flow was felt. The left cyclone was getting less flow at nozzles as compared to the right. The air flowmeters to loop seal windbox were not working. Hence quantification of air flow difference was not possible.

- The loop seal windbox pressures showed difference. The dumping valve was located close to the left side loop seal air piping. It was suspected that this could always cause higher flow in right loop seal. Hence the dumping arrangement piping was shifted to common pipe. This can be seen in figure 5.
- The loop seal trial was taken after the dumping pipe modification. Though the air flow meter indications were not proper, the downleg / riser leg flow seemed to match between left & right. Fine bed material was poured and trial taken to see the fluidisation effect.



- The line size to loop seal windbox is found to be 80 nb for down leg & 100 nb for return leg. However the butterfly damper size is 100 nb and 150 nb. Butterfly dampers can not be used for air flow regulation. They should be regulating ball valve type or else a VFD would do the flow regulation well. The dumping air valve was also 200 nb size making the air regulation difficult.
- The flow meters were not working at all. They were local indications only. The difference in airflow / loop seal plugging / breaking issues will be known if only flow meter indications are accurate and be made available at DCS. However the ranges of the meters are found to be OK. The air to be supplied to loop seal windbox is only 250 Nm³/h & 825 Nm³/h for downleg & return leg respectively. The total air flow as per Chinese documentation is 2000 Nm³/h for both loop seals put together.

Boiler operation after modification

- The PA to total flow was maintained at 57 %. Normal recommended for Indian coal is 55% to 60%.
- 8 no SA ports were closed to increase SA pressure. Yet the SA pressure touched only 2.5 Kpa at a load of 30 MW and with lean bed of 0.4 – 0.6 Kpa.

3. The loop seal WB pressures were maintained at 33-36 Kpa. The loop seal pressures were lowered on trial basis to check if ash was accumulating at cyclone. There was no accumulation. There was no slip of material / rise in bed height / rise in main WB pressure / reduction in PA flow.
4. The loop seal WB pressure was increased and checked for response on transfer rate. The bed height rise could be observed. The bed height increased too slowly indicating that the seal height was just adequate.

5. When the slag coolers were being operated, ash fines were found to be lost from the furnace. This was slowing down the fines build up which was required for

Fly ash analysis report					
Date	14.02.2018	04.03.2018			
Time	10.30 am	7.10 am	10.30 am	12.30 pm	4.30 pm
Steam Flow	130 TPH	116 TPH	116 TPH	125 TPH	135 TPH
+90 Mic	0.33%	0.37%	0.14%	0.36%	1.08%
-90 Mic to +75 Mic	1.17%	9.86%	1.48%	2.01%	4.01%
-75 Mic to +45 Mic	44.00%	56.23%	56.37%	40.90%	68.71%
-45 Mic	54.50%	33.54%	42.01%	56.73%	26.20%
	Normal	Seal broken	Normal	Normal	Normal

Table 1: The table shows the fly ash particle size analysis.

CFBC operation. Initially it was instructed to remove the bottom ash only from emergency drain but with gates in throttled condition. Later it was advised to operate one slag cooler at a time with its gate throttled.

6. The bed temperatures and excess air were coming under control as the fines were building up in the upper furnace.
7. The cyclone pressure drop was measured to be 0.45 to 0.5 Kpa at 50% MCR load.
8. In ESP field 1, ash sampling point was added. Lab was instructed to conduct sieve analysis with the 90, 75 & 45 microns sieve brought by us. The sieve analysis must be done immediately after sampling. Otherwise the result will be erratic as the ash can cake absorbing the ambient moisture. The lab ambient must be maintained

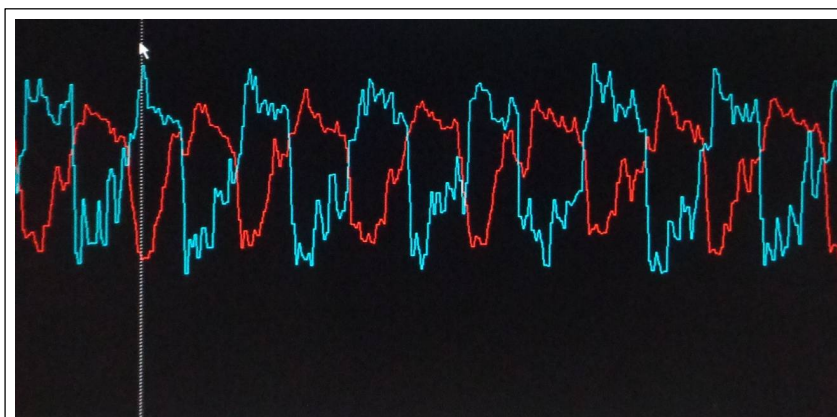

Photo 2: Trend of the bottom bed height showing spouting.

as constant temperature, say at 32 deg C. When the lab moisture varies, the result can vary. The effect is due to the CaO and MgO and other alkali elements present in ash.

9. The cyclone inlet gas temperatures & outlet gas temperatures were varying between left & right side by 4 deg C. These variations are normal. The loop seal temperatures were at least 100 deg C less than the bed temperature.
10. The boiler is not provided with stripper cooler as in other CFBC boilers. When normal drains are operated, the fines are also lost. The load raising was taking time. The upper bed DP went up to 0.7 Kpa only after 36 hours of operation.
11. We also observed that the + 90 microns in ESP ash rise when the loop seal pressure was increased to 45 Kpa. Operators were educated again to maintain the Loop seal pressure at 26 – 35 Kpa. There

was no oscillations in Cyclone. There was no oscillation of the Loop seal. The vibration levels before and now were compared & presented in table 2.

Boiler operation – Incident of low pH in boiler water

1. The water chemistry was disturbed following unusual blow down rate. There was no proper coordination in the operation of CBD valve. Due to which, the boiler water pH got reduced to 7. This seemed to have lasted for 36 hrs., before it was brought to everyone’s notice. The generation was reduced from 38 MW to 15 MW immediately. The bed temperature was kept at 750 deg in order to keep the furnace heat flux less. The pH was checked at sample cooler, at CBD and ring header drain. The load was allowed to rise only after restoration of pH.
2. During the load reduction process, the air flow was reduced. The material had drained off from Loop seal. In a hurry, the DCS operators instructed for emergency bed drain operation. When the load was to be raised, the bed was too shallow. There was one bed temperature shooting above 1040 deg C due to defluidisation. The load was immediately reduced / controlled and the bed material was fed from the bunker. The bed material added was the start up material available in the bed material bunker. Now this situation demanded a make up material bunker. This justifies the requirement to have bed material recovery and handling system.
3. From this incident, it became clear that there was no abnormal accumulation inside the cyclone. It was made clear that the loop seal pressure was the key for maintaining the seal.
4. When the bed height was too less, the loop seal broke. After the bed material addition, the seal was restored. The loop seal pressure was maintained at 26 Kpa when the load was at 25 MW.

Problem reappeared

The problem resumed in short time as the inventory was unable to be retained. The loop

Vibration measurement in cyclone & furnace								
Displacement is measured in 'mm'								
Frequency is measured in 'Hz'								
Measuring mode-FFT								
Date		17.02.2018		05.03.2018		06.03.2018		
Load		130 TPH		130 TPH		130 TPH		
		Peak dis	Freq at peak	Peak dis	Freq at peak	Peak dis		
Cyclone	LHS cyclone	Location 1	0.5	3.5	0.11	4.25	0.145	4
		Location 2	0.19	6	0.26	3.5	0.403	3
	RHS cyclone	Location 1	2.4	5	0.09	3.25	0.203	4
		Location 2	0.95	5.5	0.05	3.25	0.67	3
Furnace	LHS buckstay	Location 1	-	-	-	-	0.267	3.5
		Location 2	-	-	-	-	0.358	3.5
	RHS buckstay	Location 1	-	-	-	-	0.167	2.5
		Location 2	-	-	-	-	0.39	4
Condition of loop seal		With loop seal broken		With loop seal set OK		With loop seal set OK		

Table 2: Comparison of vibration data after stabilizing loop seal.

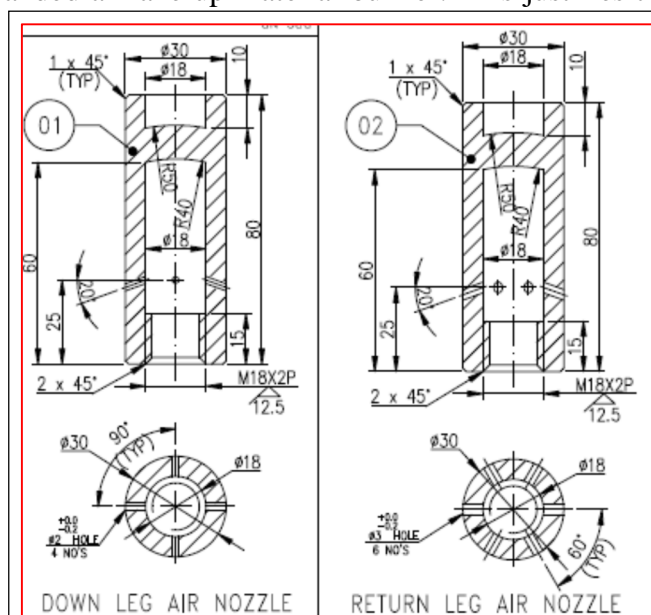

Figure 6: New nozzles designed for smoother control.

seal break continued. Then we concluded that the air flow regulation had to be refined and the air flow information is important. We advised for installation of proper air flowmeters in loop seal flow. One of the operator had prompted that the loop seal air nozzles fit up was not properly done. We guessed the air leak at the mismatched threads could result in different air flow between the two loop seals.

Replacement of loop seal air nozzles

New nozzles were designed with higher pressure drop for the downleg side. This was done to reduce the air flow to downleg side (which was otherwise leading to seal breaks) and to make the regulation easier. See figure 6 in previous page.

In order that there will be no mistake again, the air nozzles were supplied from our sister company with tight tolerance in the hole diameters. The replacement was done under our supervision. See the photos 3 & 4. In addition new flowmeters were installed in the air lines. Now the regulation of loop seal airflow from DCS was made possible. The air flow could be now set so accurately and thus the differential air flow to loop seals was rectified. The upper bed pressures were noted to be equal. The loop seal temperatures measured less as compared to be furnace temperature and cyclone inlet gas temperatures. That confirmed that seals were working well. We had introduced a loop seal height measurement as well. See figure 7. They measured to be 8 to 10 Kpa after the stabilization of operation. Six no air jets arrangements were added to aid the ash flow. This can be seen in figure 7.



Photo 3 & 4 : Misfit nozzles (earlier) and New nozzle (being fitted).

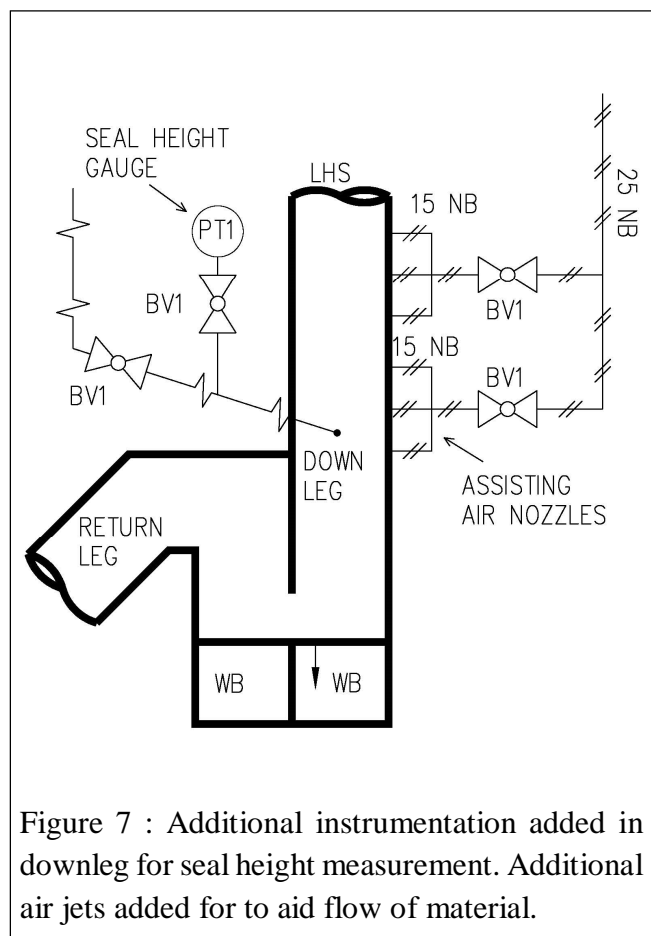

Figure 7 : Additional instrumentation added in downleg for seal height measurement. Additional air jets added for to aid flow of material.

Photo 5 shows the old flowmeter. Photo 6 shows the new orifice flowmeter added for remote indication of loop seal air flows and the control valves added for remote control purpose. This helped the operators to a great extent. The control of loop seal was very much in their hands now.

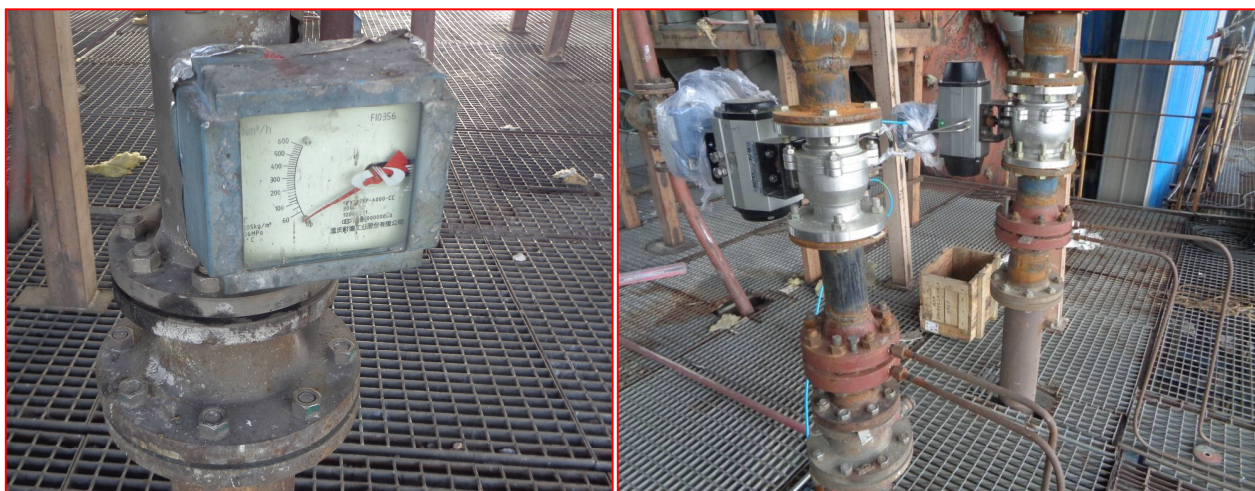

Photo 5 & 6 : Old local flowmeter and new remote control valve & flowmeter.

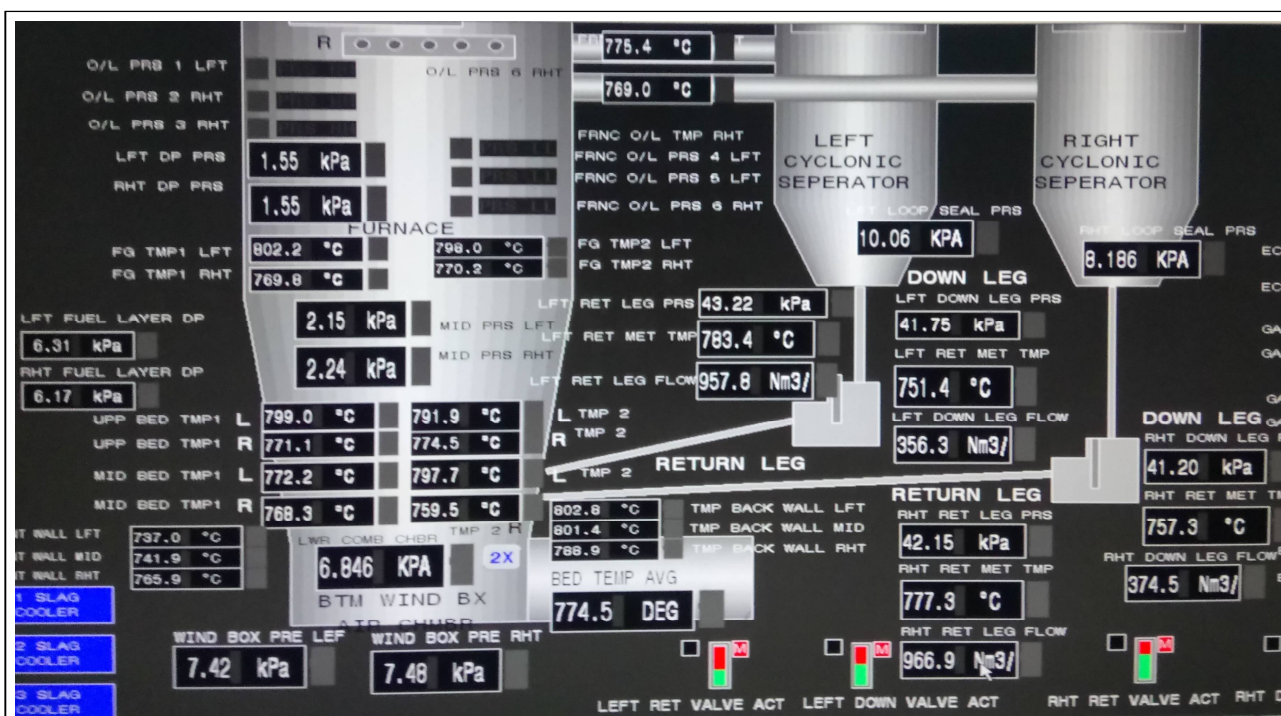

Photo 7: Screen shot after the loop seal air nozzles were rectified.

Conclusion

At the end, the nightmare was gone. The blow out phenomenon was gone. As the refractory was getting smoothed, the air flow assistance nozzles were gradually closed. The plant engineers ultimately mastered the CFBC technology. In the end the plant was commissioned the right way after 3 years.